



400 SERIES FRYERS

E421 F2X Twin Pan Fryer with Twin Filtration

Key features

- High performance elements
 - Quick heat up and rapid recovery times
 - Reduces energy consumption and running costs
- Automatic two-stage filtration built in per pan
 - Increases oil longevity and maintains quality
- 3 stage switch on
 - Prompts operator to check oil level before switching fryer on
- Temperature range between 130 - 190°C
 - Variable, precise control
- Unique pan design requires just 10 litres of oil
 - Easy to clean as well as being energy efficient and saves money on oil
- Manual controls
 - Easy and straightforward to use
- Stainless steel hob with mild steel pan
 - Robust construction to withstand busy demands
- Fast-acting safety thermostat
 - Power cut to unit if oil overheats
- Supplied with fish grids, baskets and lid
 - Everything you need to start frying
- Supplied with drain bucket, strainer and filter per pan
 - Essential parts of the filtration process

Accessories

- Sidescreens

Similar Models

- E421X Twin pan electric fryer
- E421FX Twin pan fryer with filtration
- E422FX Twin pan programmable fryer with filtration



FRYER ANGEL

The unique *Falcon Fryer Angel* safety system prevents fryer fires, making it a must-have for any commercial kitchen.

The most common causes of fryer fire occur when oil levels are too low during cooking or when the appliance is switched on without the operator checking to see if there is enough oil in the pan. The *Falcon Fryer Angel* eradicates this by simply cutting power to the unit if the oil level is not at a sufficiently high level.

The Falcon Fryer Angel - making your kitchen safer!

Patent applied for, Patent Application No. 2002725.6 (UK), PCT/GB2020/050462 (International)

Twin Pan Fryer with Filtration

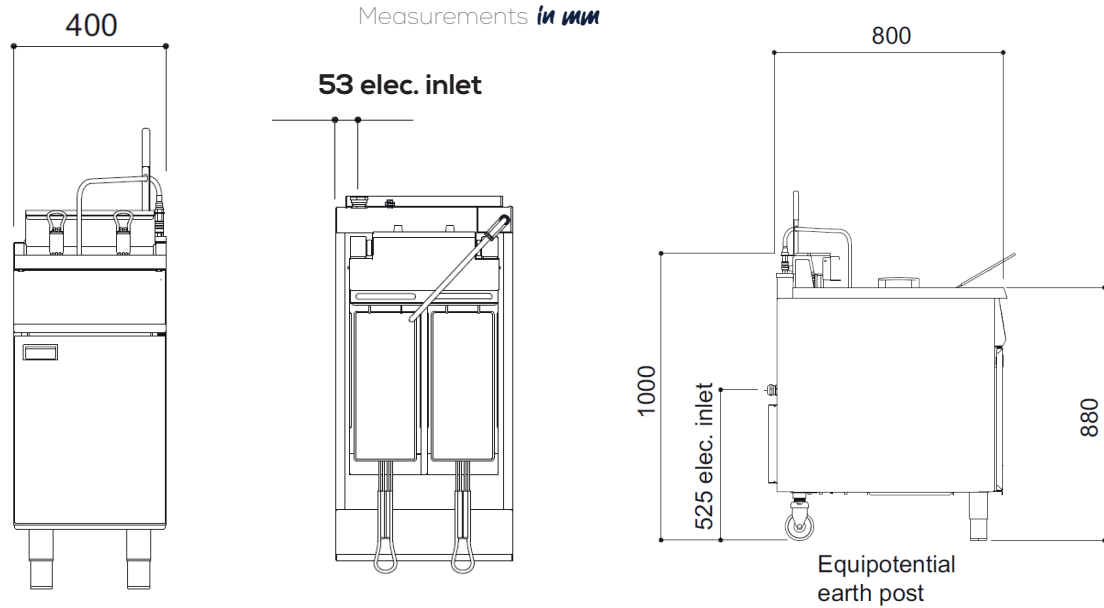

Specification details

Electrical rating (kW)	20
Electrical supply voltage	400V 3N~
Required electrical supply 400V (A)	32
Electrical current split (A)	L1: 29 L2: 29 L3: 29
Oil capacity (litres)	2 x 10
Hourly chip output (kg)	2 x 25
Weight (kg)	86
Packed weight (kg)	95
Packed dimensions (w x d x h - mm)	450 x 1000 x 1100
GTIN number	5056466906955

Installation notes

Adequate ventilation must be provided to supply sufficient fresh air and to allow easy removal of any such products that may present a risk to health. Please consult current legislation for details that relate to specific locations.

Install unit on a level, fireproof surface in a well-lit position. If floor is made of a combustible material, local fire requirements must be checked to ensure compliance.

A clearance of 150mm should be observed between appliance and any combustible wall.

