



E600 Rise and Fall Grill



Short Form Specification

Unit to be Falcon F900 Series rise and fall grill that may be wall-mounted or installed upon a table.

Unit will be operated manually or by programmable function controlled by touch screen.

Unit will have a dish detection function and the grill canopy can be adjusted in height to be in the proximity of the food being cooked.

Exterior panels are stainless steel.

Key Features

- Instant heat delivered by powerful infra-red elements
- Automatic plate-sensing technology saves energy
- 1/1 gastronorm compatible
- One touch operation
- Manual or programmable mode
- IPX 3 water resistance certification
- One touch operation
- Manual or programmable mode

Accessories

- Bench legs



E600 Rise and Fall Grill

Model Dimensions (mm)

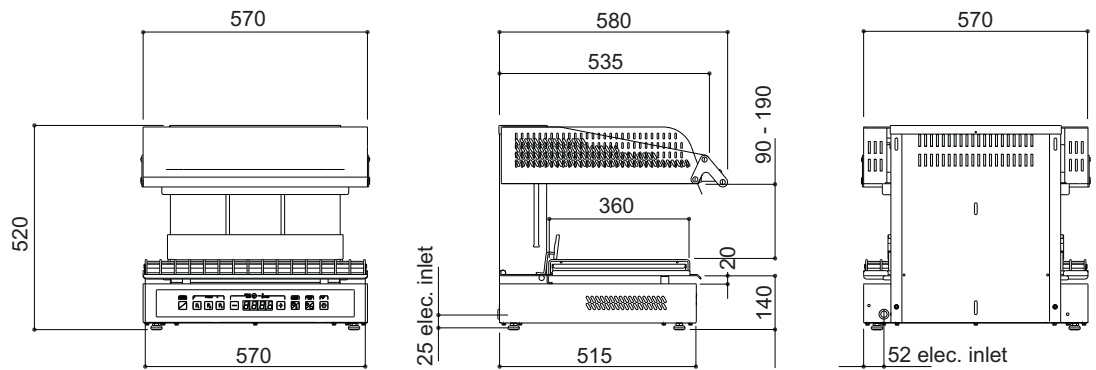

Cooking Area is 560 x 360

Specification Details

| | |
|--|--------------------------------|
| Electrical rating (kW) | 4.2 |
| Electrical supply voltage (V) | 400V 3N~ 50/60z or 230V~ |
| Required electrical supply - 400V 3N~(A) | 32 |
| Phase split - 400V 3N~ (A) | L1: 6.52 / L2: 6.52 / L3: 6.52 |
| Phase split - 230V~ (A) | 19.56 |
| Weight (kg) | 69 |
| Packed weight (kg) | 75 |
| Packed dimensions (mm) | 680 (w) x 650 (d) x 730 (h) |

Installation Note:

Please consult local legislation with regard to installation of cooking equipment.

