

# Falcon Xpress Ovens



## Falcon Xpress JET

### High Speed Oven

#### Combines cooking energies for superior baking results **FAST!**

- 2700W Convection enhances toasting and browning
- 95°– 250°C temperature range
- 1400 or 1900W top antenna feed microwave system heats quickly, reduces cooking time
- Flexible cooking platform. Use any combination of convection and microwave

#### Simplifies cooking

- **Ventless Options:** "V" models feature built-in catalytic converter for ventless operation
- Stackable without a kit, to increase throughput and save valuable counter space
- 34 litre oven capacity easily accommodates a 12" pizza

#### Multi-language universal operation, with programming flexibility

- Oven interface and programming software support 20 languages
- Smart USB connectivity standard
- Compatible with ACP Programming Application
- Stores up to 100 programmable menu items

#### Cuts Costs

- Uses less energy than a conventional oven
- Eliminates need for pre-cooking and holding
- Uses quarter-size metal trays, pans and screens

#### Easy to Use and Maintain

- Stainless steel exterior and interior
- Door opens 90°+ for full access to the oven cavity

**Falcon Xpress Jet | Heavy Volume**  
This category of high speed oven is ideal for...

#### Applications

- Cafés
- Bakeries
- Wine bars
- Pubs
- Supermarkets
- Convenience stores
- Sports clubs
- Kiosks

#### Throughput potential by oven wattage (Qty/hour)

Food item	1400W	1900W
Chocolate Cake	36	36
Steak Pie	15	19
Baked Brie	14	16
12" Pizza	12	15
Large Baked Potato	9	11

#### Location of Oven(s)

- Kitchen shelf
- Kitchen counter top, single or stacked
- Equipment stand, single or stacked

All Falcon Xpress products are supported by our culinary team. Do not hesitate to contact us for any questions regarding food preparation, menu development and cooking times:

[chef@falconfoodservice.com](mailto:chef@falconfoodservice.com)



#### Optional Accessories

- Oven paddle (PA10)
- Magnetic air filter (AF10)
- Panini grill plate (JR10)
- Pizza Stone (ST10C)
- Drip Tray/Griddle (DR10)
- Non-stick baskets
- Non-stick cavity liners (TL12)
- Oven floor liner (OV10)
- Stainless cart/equipment stands
- Oven Cleaner & Shield
- Replacement oven rack (RA14)

# Falcon Xpress JET | High Speed Oven

front view

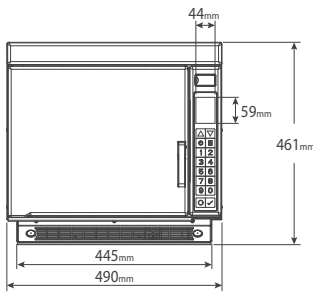

side view

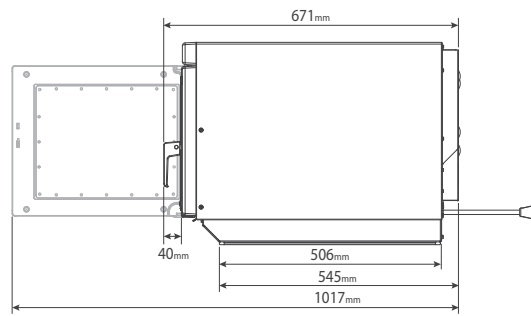

back view

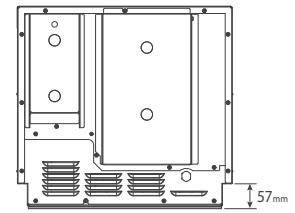

Dimensions			
Exterior	H 461	W 490	D† 671
Oven	H 267	W 330	D 381
Usable Oven Space	34 litres		
Door Depth	1017, 90°+ door open		
Installation Clearance	Top: 102	Sides: 25	Back: None
Shipping Carton	H 546	W 540	D 756

Weight		
Model Type	Product Weight	Ship weight (approx.)
With catalytic converter	51 kg	53 kg
Without catalytic converter	50 kg	52 kg

Features	
Configuration	Countertop
Stackable	Yes, without kit
Display	71 Colour LCD
USB Port	Yes
Internet Connectivity	No
Control System	Touchpad
Programmable Control	Yes, 10 pads
Braille	Overlay available
Settings Programmable	100
Temperature Range	95°– 250°C
Microwave Distribution	Rotating antennas, top
Power Levels	11
Defrost	Yes, microwave only, power level 2
Time Entry Option	Yes
Stage Cooking	Yes, 4 stages
Air Filter	Non-removable with cleaning reminder**
Rack	2 positions, 1 removable rack
Door Handle	Lift & Pull
Exterior Finish	Stainless steel
Interior Finish	Stainless steel

A type D circuit breaker should be installed for all high-speed oven installations.



Measurements are millimeters.

\* IEC 60705 Tested

\*\* Removable magnetic air filter accessory available (#AF10)

† Includes handle

‡ Catalytic converter filters grease and odours from the air. This product conforms to the Ventless Operation Recommendations set forth by NFPA96 using EPA202 test method

Model Number / Product Code	Max. Cooking Time	Catalytic Converter	Power Consumption	Power Output		Power Source	Plug Configuration	Cord Length	Frequency	Magnetron
				Microwave*	Convection					
JET519V3F 710632612	16:00	Yes‡	6200W, 14A	1900W*	2700W	400V, 50Hz, 16A, 3phase, 5wire	IEC 309 	2.4 m	2450MHz	2
JET514UF 710632512	20:00	No	2400W, 11A	1400W*	2700W	230-240V, 50Hz, 13A, single phase	BS1363A 	1.5m	2450MHz	2

