



VARIO-THERM

E1011 Regen Oven

Key features

- Digital timer and thermostat
 - Precise time and temperature control
- Twin fans within oven chamber
 - Delivers even cooking across the chamber
- Fast heat up and recovery times
 - Speeds up the overall cooking operation
- 1/1 gastronorm compatible
 - Accomodates industry standard trays & shelves
- 10 shelf capacity
 - Designed for bulk production
 - 10 shelves supplied
- Full stainless steel construction
 - Easy to clean
- Supplied on stand as standard
 - More convenient working height and valuable storage space below
- Supplied fully-factory assembled
 - Easy to install
- Different power options available
 - Choose the one that suits your facility

Accessories

- Additional oven shelf
- Stand shelf runners
- Feet for stand



Measurements *in mm*

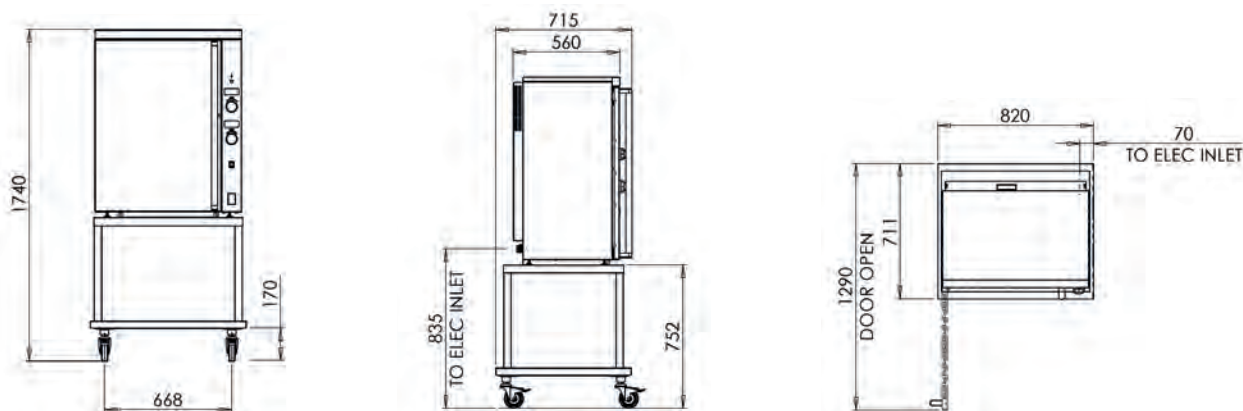

Specification *details*

	Single Phase Dual Supply	Single Phase (32A)	3 Phase (16A)
Electrical rating (kW)	5.4	5.4	5.4
Electrical supply voltage	230V 1N~ x 2	230V 1N~	400V 3N~
Required electrical supply (A)	2 x 13	1 x 32	1 x 16
Electrical current split (A)	Feed 1 L: 11.5, Feed 2 L: 11.9	L: 23.4	L1: 11.5, L2: 11.9, L3: 0
Oven element rating (kW)	5.4	5.4	5.4
Oven dimensions (w x d x h - mm)	546 x 370 x 810		
Oven shelf (w x d - mm)	546 x 370		
Grid shelf capacity	10 (10 supplied)		
GN compatibility	1/1		
Weight (kg)	115		
Packed weight (kg)	130		
Packed dimensions (w x d x h - mm)	900 x 750 x 2000		

GTIN *numbers*

E1011 - 1 phase dual supply	E1011 - single phase (32A)	E1011 - 3 phase (16A)
5056466906825	5056466906832	5056466906849

