

Cook & Hold Oven

Model 750-TH

Original Cook & Hold Ovens produce better food quality and higher yields with built-in savings.

Gentle, radiant Halo Heat® technology evenly surrounds food without the use of extremely hot elements, added humidity or fans. This controlled, uniform heat maintains precise temperatures throughout the cooking and holding process—improving food quality and extending hold times.

Cook by time or probe with Simple or Deluxe controls. Probes sense internal product temperature and automatically convert the oven from cook mode to hold mode once set parameters have been reached.

Labor-free, overnight cooking and effortless operation reduces labor costs and increases productivity.

Place anywhere with a ventless, waterless design. Lower costs with energy efficient operation and no water hookups or traditional kitchen hood required. All Alto-Shaam Cook & Hold Ovens are EPA 202 Certified ventless.

Advanced controls – designed intentionally simple – feature an intuitive, user-friendly interface and programmable recipes to ensure consistency with each cook.

ChefLinc™, cloud-based remote oven management software, streamlines processes and maximizes profits with data-driven insights [Deluxe model only].

ISO 9001:2015-certified

Standard Features

- Casters (two [2] rigid, two [2] swivel with brake)
- Single-point, straight removable probe
- Drip tray and drip pan with drain
- Programmable, touchscreen control on Deluxe model
- HACCP data collection on Deluxe model
- Programmable control on Simple model
- Easy recipe upload/download via USB port
- SureTemp™ heat recovery on Deluxe model
- Two [2] stainless steel side racks with ten [10] pan positions spaced 35mm on centers
- Removable exterior drip tray



CAPACITY

10 GN 1/1 — 530mm x 325mm x 65mm

20 GN 1/2 — 265mm x 325mm x 65mm

Weight maximum: 45 kg
Volume maximum: 71 liters

Three [3] shelves included. Additional shelves required for maximum capacity.



Lifetime Warranty

On all Cook & Hold heating elements (excludes labor)



CE EAC IP X4

ALTO-SHAAM



Shown with Deluxe control



Shown with Simple control

750-TH

Configurations (select one each)

Models

- Simple
 - HACCP option
- Deluxe
 - Ethernet option [5032090]

Door Choice

- Right hinged, solid door, standard
- Right hinged, window door
- Left hinged, solid door
- Left hinged, window door

Electrical

- 230V, 1PH

Casters and Legs

- 64mm casters, two [2] rigid two [2] swivel with brake, standard [5027134] – not available with bumper
- 64mm caster, swivel with brake, option [CS-39969, 4 required] – not available with bumper
- 89mm casters, two [2] rigid two [2] swivel with brake, option [5027133]
- 89mm caster, swivel with brake, option [CS-39971, 4 required]
- 127mm casters, two [2] rigid two [2] swivel with brake, option, [5027112]
- 127mm caster, swivel with brake, option [CS-39973, 4 required]
- 152mm legs, set of four [4] [5032092]
- 152mm seismic legs, set of four [4] [5032093]

Optional Accessories (select all that apply)

Bumper and Handles

- Full perimeter bumper
- Push/Pull handle

Additional Probes

- Sous vide probe [PR-36576]
- T-handle probe, up to six [6] with Deluxe [PR-46998]
- Straight probe, up to six [6] with Deluxe (qty one [1] included with oven) [PR-46999]

Drip Pans, Shelves, Holders

- Drip pan with drain [5027713]
- Drip pan, without drain [1034370]
- Increased capacity exterior drip pan [5030664]
- Shelf, stainless steel [SH-2324]
- Carving holder, prime rib [HL-2635]
- Carving holder, steamship [cafeteria round] [4459]

Cleaners

- Alto-Shaam, non-caustic cleaner one [1] 1-liter bottle [CE-46828]
- Alto-Shaam, non-caustic cleaner six [6] 1-liter bottles [CE-46829]

Accessories, misc.

- Stacking kit, 750-TH over 750-TH [5032041]
- Door lock with key [5028755]

Cook & Hold Oven

Model 750-TH

ALTO-SHAAM.



DIMENSIONS

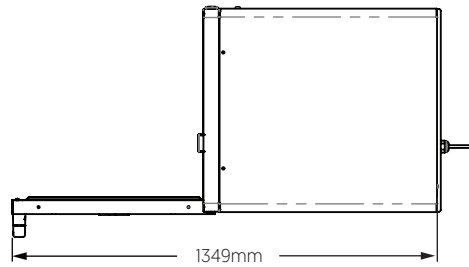

Shown with Simple control and 89mm casters

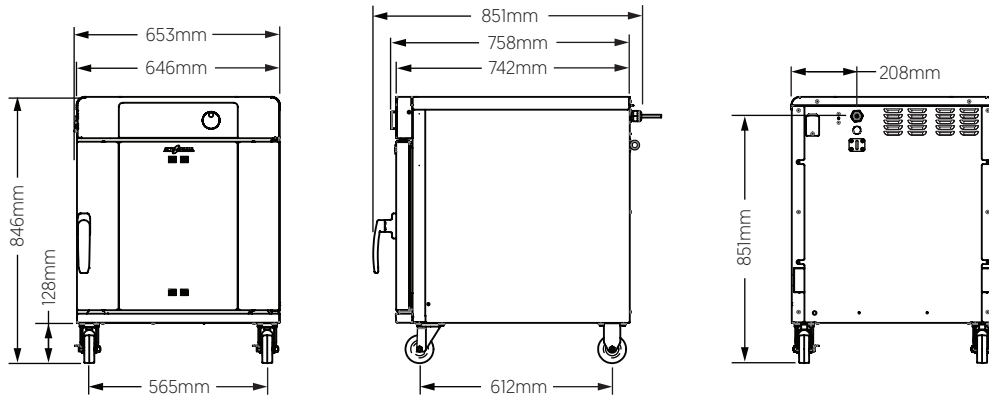

OVERALL HEIGHT: 750-TH	
Accessory	mm
127mm caster	873
89mm caster	846
64mm caster	805
152mm leg [min]	818
152mm leg [max]	875
152mm seismic leg [min]	842
152mm seismic leg [max]	904

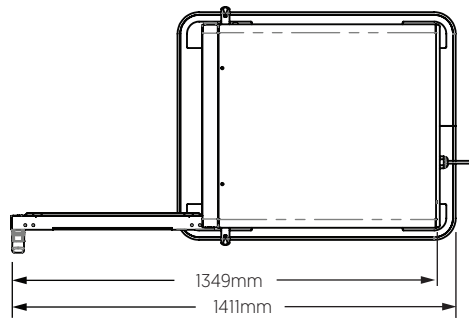

Shown with Deluxe control, 127mm casters, bumper, and handles

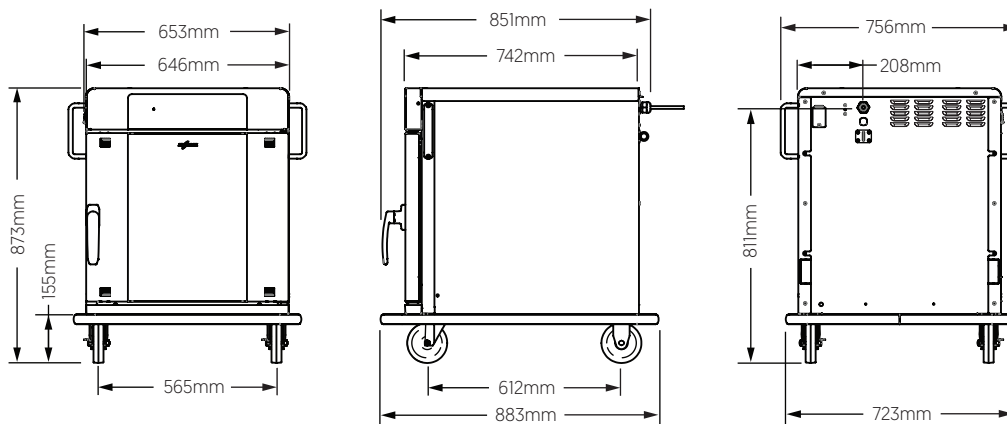

Interior (H x W x D)	Net Weight	Ship Dimensions (L x W x H)	Ship Weight
510mm x 559mm x 673mm	102 kg	889mm x 889mm x 1067mm	131 kg

Cook & Hold Oven

Model 750-TH



CLEARANCE

Top:..... 51mm
 Left: 51mm
 Right:..... 51mm
 Back:..... 76mm



CHECK FIRST

The oven must be installed level.
 The oven must not be installed in any area where it may be affected by steam, grease, dripping water, high temperatures, or any other severely adverse conditions.



HEAT

Heat of rejection

750-TH	Heat Gain qs, BTU/hr	Heat Gain qs, kW
	851	0.25



TEMPERATURE

Cooking temperature range:

94°C–163°C

Holding temperature range:

29°C–96°C



ELECTRIC

750-TH	V	Ph	Hz	Awg	IEC	A	Breaker (A)	kW	Plug Configuration	Certification
120V	120	1	60	10	—	14	20	1.7	Alto-Shaam offers a number of readily available cord and plug configurations. Contact factory for options.	
208–240V**	208	1	60	10	—	15	20 UL 30 CSA	3.1		
	240	1	60	10	—	17	20 UL 30 CSA	4.2		
230V	230	1	50/60	10	—	17	32	3.8		
		1	50/60	10	—	11	20	2.6*		

Electrical connections must meet all applicable federal, state, and local codes.

*Reduced wattage configuration.

**Dedicated circuit required.

CONTACT US

W164 N9221 Water Street | Menomonee Falls, Wisconsin 53051 | U.S.A.
 Phone: 262.251.3800 | 800.558.8744 U.S.A./Canada | Fax: 262.251.7067 | alto-shaam.com