

Autofill Countertop 5L With Built in Filtration



Product Code	069764
Model no.	AFF5CT
EAN Barcode	5011139069764
Product type	Autofill Boiler
Warranty Period	2 years parts & labour

Technical Information

Product Info:

Filtered	Yes
Capacity (litres)	5
Packed Dimensions (WxDxH, mm)	432x490x546
Drip Tray Dimensions (WxDxH, mm)	344x195x50
Product Weight (kg)	8.3
Packed Weight (kg)	11
Colour	Bright Annealed Stainless Steel & Black
Body Construction / Material	430 Stainless Steel
Tank Construction / Material	304 grade Stainless Steel
Trim and drip tray plastic type	PC ABS
Tap Material type	Chrome
Dual Function Tap	Yes
Safety Standards test	EN60335
Nonslip Feet	Yes
Boil Dry cut-out	Yes

Performance:

Heat up Time to 98°C (minutes)	22.5
Rapid Draw off—Litres	5.7
Rapid Draw off—Pints	10
Rapid Draw off—Cups	37
Output per Hr—Litres	31
Output per Hr—Pints	55
Output per Hr—Cups	206
Recovery Per min—Litres	0.5
Recovery Per min—Pints	0.88
Recovery Per min—Cups	3.3
Heat up time 70°C—98°C (minutes)	6.5
Cool down time 98°C—70°C (minutes)	376
Standard power consumption (kW/hr)	0.12

Installation:

Hard wiring required	No
UK fitted plug	Yes
Cable length (m)	1.5
Water feed pipe length (m)	2
Max. water inlet pressure (bar)	8
Element power rating	2.8
Phase type	Single
Nominal voltage	230V 50-60Hz
Electrical supply current (A)	13
Water inlet connection fitting	3/4" BSP

Water Boiler Features

- Replaceable water filter provides better tasting beverages and reduces limescale buildup..
- Desired water temperature can be easily set between 98°C down to 70°C for more delicate speciality teas.
- Will dispense upto 206 cups per hour / 31 litres, with 5.7 litre rapid draw-off.
- The boilers eco-mode can be programmed to suit the location, reducing running costs and saving energy.
- Robust chrome tap, can be switched between controllable and constant flow with 170mm tap height above tray.
- Compact 450mm overall height, ideal for counter spaces with limited headroom.

Dimensions (mm)

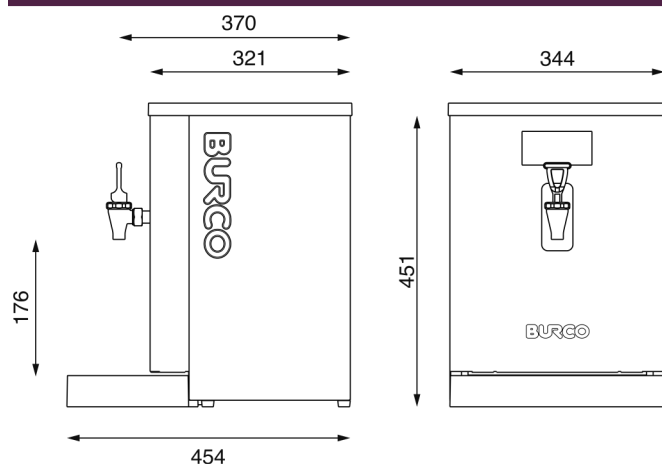

Glen Dimplex Heating & Ventilation, Millbrook House, Grange Drive, Hedge End, Southampton, SO30 2DF